

## Safe and reliable

- ◆ Safe and worry-free: The full hydraulic braking system is reliable and maintenance-free;
- ◆ Core components are reliable, durable and value maintained: A new generation of predictive maintenance technology can monitor the hydraulic oil pollution, fuel-water separator in real time, intelligently prompt maintenance and trouble shooting to ensure healthy and stable operation of equipment.

## More comfortable driving

- ◆ Warm in winter and cool in summer: The cab is fully covered with interior trims, having three dimensional surround air outlets. Our standard equipped heating and air conditioning system allows comfort for the operator in hot and cold conditions.
- ◆ Long-time vibration driving without fatigue: The new generation of cab has a improved suspension and reduced noise emissions. Integrated with a 7-inch touch LCD color screen and electric control handle and air suspension seat.
- ◆ Smooth operation: The electronic control technology is adopted to adjust the driving parameters during reversing in real time, which makes the operation more stable and smooth.



**C10 Series**



**SANY HEAVY INDUSTRY CO., LTD.**

Sany Industrial City, Changsha Economic and Technological Development Zone, Hunan Province, China  
Zip: 410100  
Fax: 0086-731-85835199 Enquiry and Complaint Telephone: 0086-4006098318

Warm reminder:  
As the technology is constantly updated, technical parameters and configurations are subject to change without prior notice.  
The machine on the picture may include additional equipment, this album is for reference only, subject to the actual.  
The copyright belongs to SANY Heavy Industry, and no part of this catalog may be reproduced or copied for any purpose without SANY Heavy Industry's written permission.

© China print Apr. 2025 edition



Scan the QR code to follow  
the WeChat Official Account of  
SANY Road Machinery

V.20250409

**SANY**<sup>®</sup>

# SPECIFICATION



## Road roller SSR130C-10H

QUALITY CHANGES THE WORLD  
[www.sanygbbal.com](http://www.sanygbbal.com)

## Product Highlights

The SANY single drum roller SSR130C-10H with full-hydraulic dual-drive has strong climbing and compaction capabilities, especially suitable for compacting under working conditions such as large thickness subbase, sandy land and steep slopes.

### Strong climbing and Breakout capability

- ◆ Climbing capability of 50%: Driven synchronously by steel drums and tyres, equipped with standard diamond tyres and ASR (Anti-Slip Regulation) system to effectively avoid slipping, suitable for compaction on steep slopes.
- ◆ Strong breakout capability, suitable for all-terrain compaction: 4-gear working speeds and independent adjustment of the driving force of the steel drum and tires to effectively improve breakout capability from sandy land, wet soil, and steep slopes during compaction.

### High-efficiency energy-saving technology

- ◆ Fixed-frequency variable speed technology (Economy Mode): Optimizes engine performance through vibration control logic adjustments while maintaining frequency stability, achieving high efficiency and energy saving.

### Easy service

- ◆ The engine/hydraulic filter elements are arranged in a centralized manner, and can be quickly replaced by standing on the ground without climbing.



## SSR130C-10H

Road roller  
C10 Series

### Dual-drive ASR (Anti-Slip Regulation) system

- ◆ Parallel drive of steel drum and tyres, automatic shunting to ensure synchronous compaction, large speed ratio reducer and rear axle to ensure 50% climbing capability.
- ◆ With dual-drive and dual-control technology, the driving force of steel drum and tyres can be controlled separately to effectively solve the problem of slipping of steel drum or tyres and improve the breakout capability.
- ◆ ASR system can accurately distribute the front and rear driving force in real time according to the ground adhesion, which is suitable for sandy land, wet soil and slope working conditions.



### Energy-saving technology of vibratory road roller

- ◆ Fixed-frequency variable speed technology, which matches the best fuel consumption point of the engine in real time to reduce fuel consumption.
- ◆ Vibration peak clipping, accelerating from 0 to stable frequency in steps, so as to reduce the peak power when starting vibration.
- ◆ Driving peak clipping and flexible starting to reduce peak power during driving.

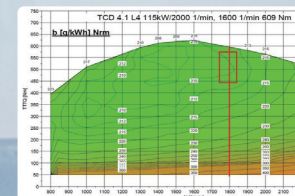

### A new generation of intelligent control system

- ◆ The third generation of intelligent controller, with response time up to millisecond level.
- ◆ The 7-inch touch integrated display and control LCD screen is characterized by simple operation, accurate control and clear interface; the universal adjustment display screen can be adjusted at will.
- ◆ A new generation of silicone buttons, integrated with backlight and indicator light, is convenient for night construction.
- ◆ Easy service: The engine/hydraulic filter elements are arranged in a centralized manner, and can be quickly replaced by standing on the ground without climbing.

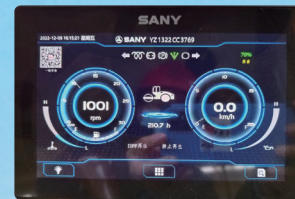

### Ergonomic cab and vibration reduction technology

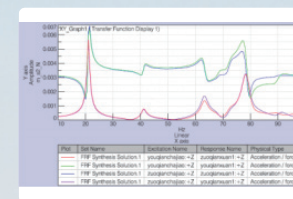

### Product configuration option and intelligent kit

Item	Description of additional/optional configuration
Reversing camera (standard configuration)	Used to monitor the safety situation behind the body
assembled lug	Used for compacting clay with high water content
Intelligent kit	Used for online detection of compactness on construction site
Wear-resistant steel drum	Used for rock construction scene of hydroelectric dam
Obstacle avoidance of intelligent reversing radar	Meet the user's safety requirements
Tyres of different tread types	Used to meet the needs of various construction sites
ASR (Anti-Slip Regulation) system	Used for sandy land and wet soil compaction to avoid slipping of steel drum or tyres

### Intelligent supporting facilities and services

#### Intelligent compaction assistance system



Real-time detection of compaction parameters (ICV compaction value, amplitude and vibration frequency).  
It is displayed in real time through the on-board display screen to simplify installation.

## Product Parameters

### Overall Dimensions

The following are standard configuration measurements; actual values may vary depending on optional components.

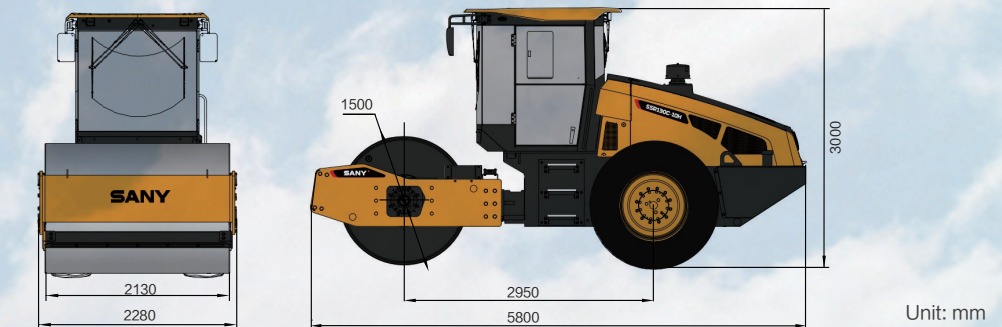

Unit: mm

Item	SSR130C-10H
Engine manufacturer	Deutz
Type	TCD4.1
Emission stage	Stage V
Rated power/speed (kW/rpm)	115/2000
Operating weight CECE w. ROPS-cabin (kg)	13000
Front / Rear load CECE (kg)	7100/6000
Static linear load CECE (N/cm)	333
Frequency (Hz)	30/35
Amplitude (mm)	1.8/0.9
Centrifugal force (kN)	280/178
Drum diameter/width (mm)	1500/2130
Max. gradeability without vibr. (%)	50
Fuel tank volume (L)	220

